



Stichting NIOC en de NIOC kennisbank

Stichting NIOC (www.nioc.nl) stelt zich conform zijn statuten tot doel: het realiseren van congressen over informatica onderwijs en voorts al hetgeen met een en ander rechtstreeks of zijdelings verband houdt of daartoe bevorderlijk kan zijn, alles in de ruimste zin des woords.

De stichting NIOC neemt de archivering van de resultaten van de congressen voor zijn rekening. De website www.nioc.nl ontsluit onder "Eerdere congressen" de gearchiveerde websites van eerdere congressen. De vele afzonderlijke congresbijdragen zijn opgenomen in een kennisbank die via dezelfde website onder "NIOC kennisbank" ontsloten wordt.

Op dit moment bevat de NIOC kennisbank alle bijdragen, incl. die van het laatste congres (NIOC2025, gehouden op donderdag 27 maart 2025 jl. en georganiseerd door Hogeschool Windesheim). Bij elkaar zo'n 1500 bijdragen!

We roepen je op, na het lezen van het document dat door jou is gedownload, de auteur(s) feedback te geven. Dit kan door je te registreren als gebruiker van de NIOC kennisbank. Na registratie krijg je bericht hoe in te loggen op de NIOC kennisbank.

Het eerstvolgende NIOC vindt plaats op 18 maart 2027 in Arnhem en wordt georganiseerd door HAN University of Applied Sciences.

Reacties over de NIOC kennisbank en de inhoud daarvan kun je richten aan de beheerder:

R. Smedinga kennisbank@nioc.nl.

Vermeld bij reacties jouw naam en telefoonnummer voor nader contact.

A Two-Perspective Visualization Approach for Utilizing Visualization Power in Computer Science Education

Ragaad AlTarawneh
Shah Rukh Humayoun

Kaiserslautern University
Germany

Why Visualization?

- The visualization is a graphical representation of information to see the hidden details.

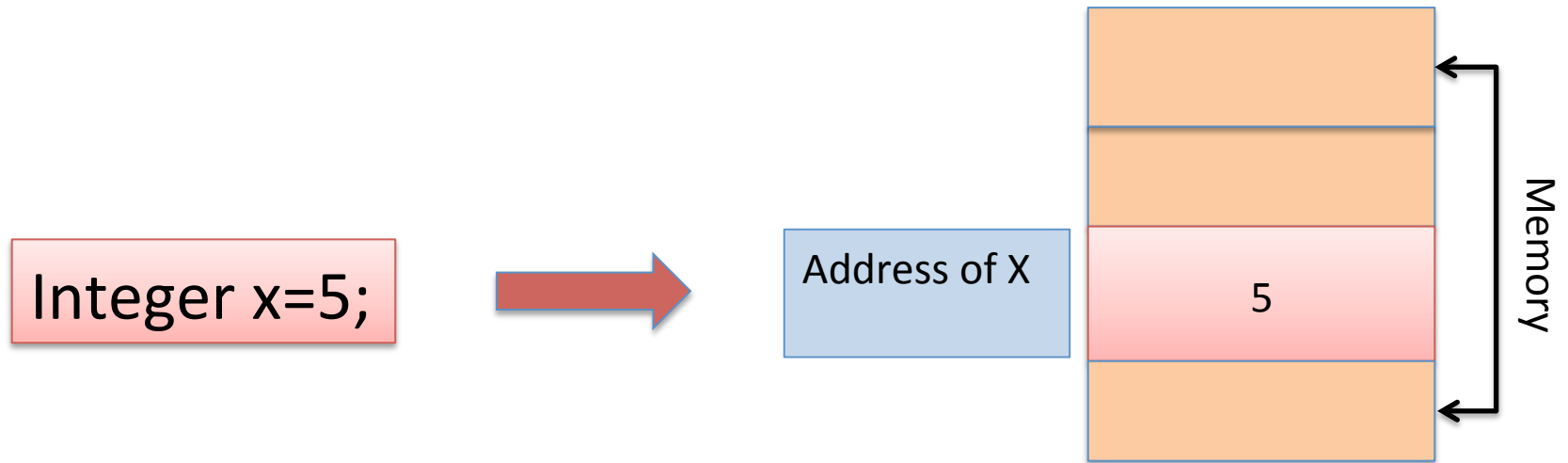

Static Visualization Perspective

- The static visualization perspective is related to producing a visual form that doesn't change over time.
- Pros:
 - It helps in retrieving the required information faster.
 - Producing such visualizations doesn't need much time or effort to achieve.
- Cons :
 - Students cannot interact with it directly.

The Static Visualization Perspective Example

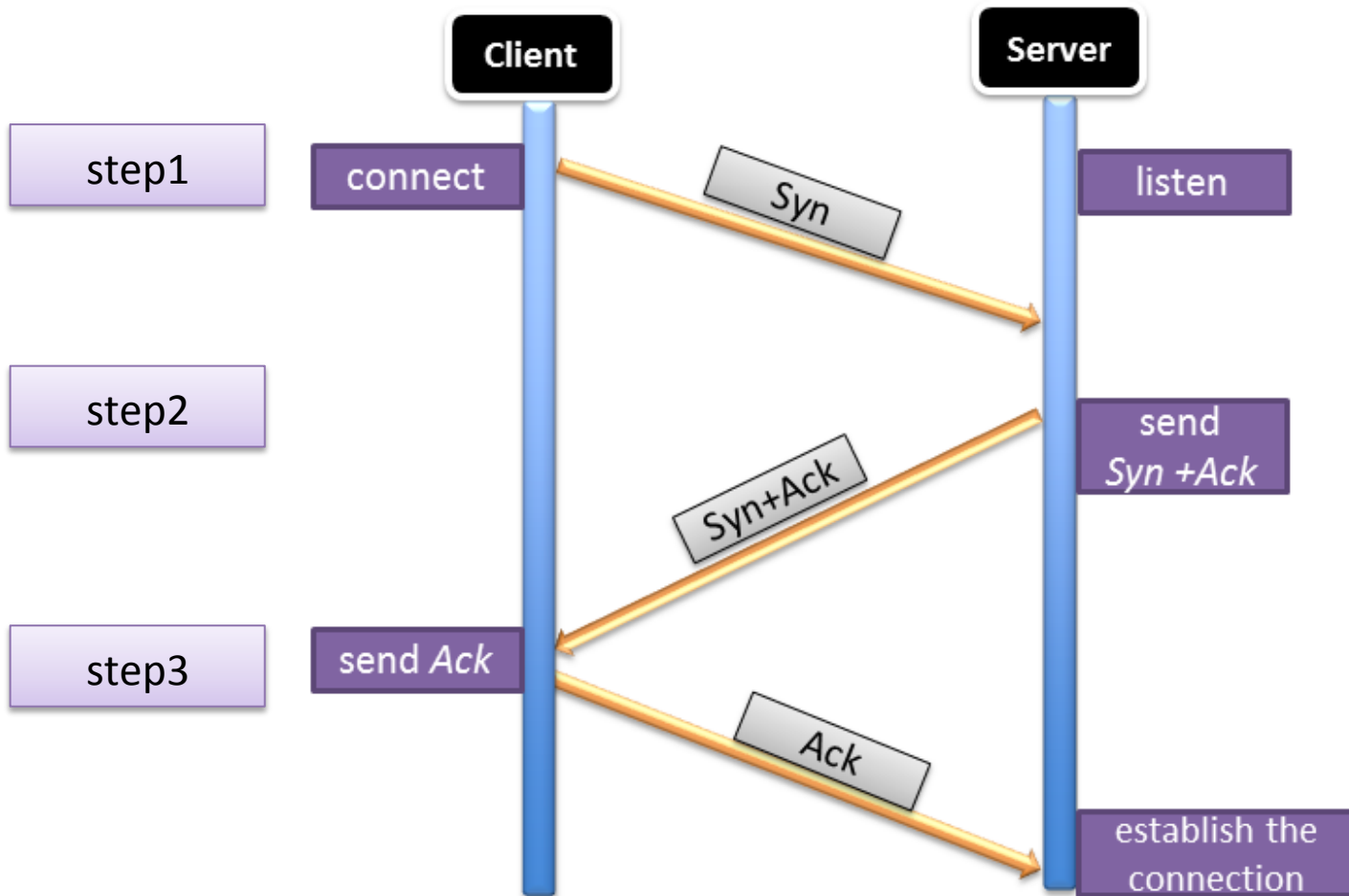

The Dynamic Visualization Perspective

- Produces a visual representation representing the concept behavior.
 - Design a simulation representing the behavior of the underlying concept.
 - Define the set of parameters related with the concepts.
 - Provides some interaction techniques so students get more

The Dynamic Visualization Perspective

- The simulation requires both
 - Calculating the parameters of the concept
 - Mapping the calculated parameters to visual cues
 - Matching with the concept domain.
- The final visual representation can be used to:
 - convey some facts about the underlying concept
 - Convey the relations between the different parameters that influence each other in the specified topic.

A Dynamic Visualization Perspective Example

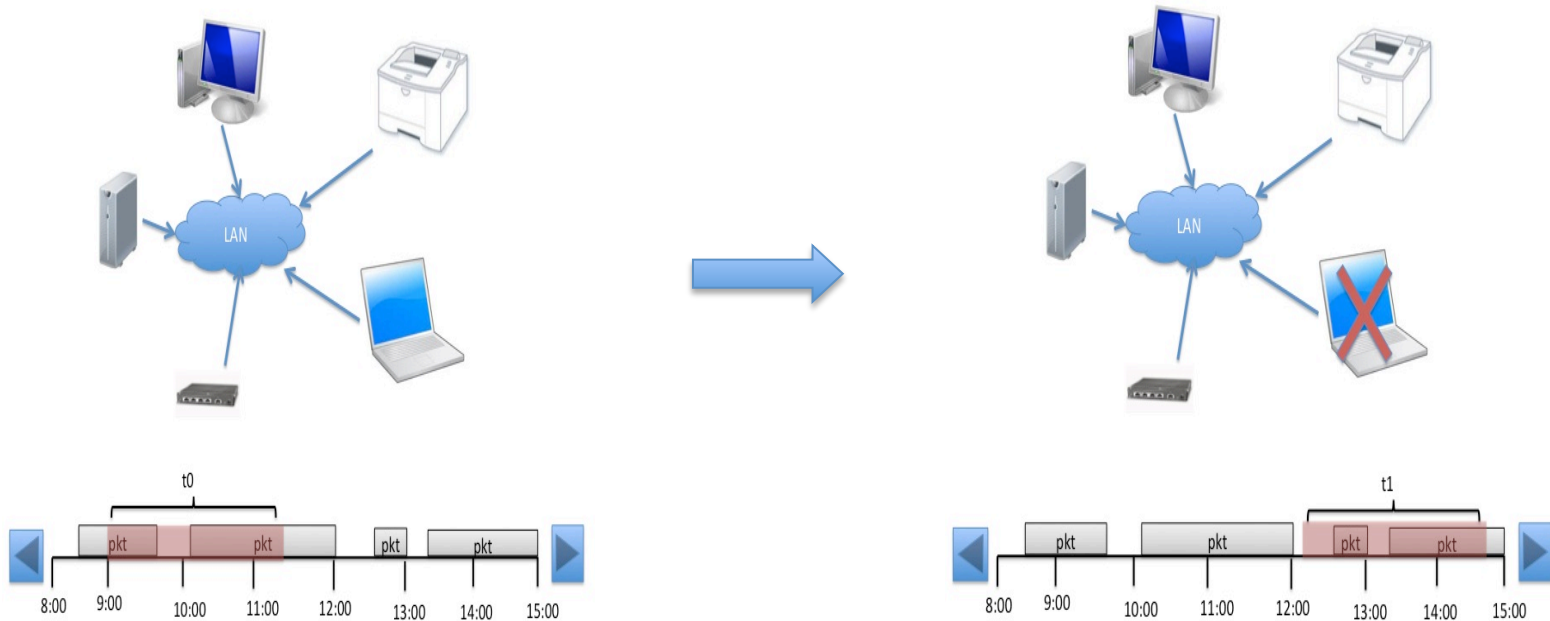

The visualization represents the network status at t_0

The visualization represents the network status at t_1

The Visualization Pipeline

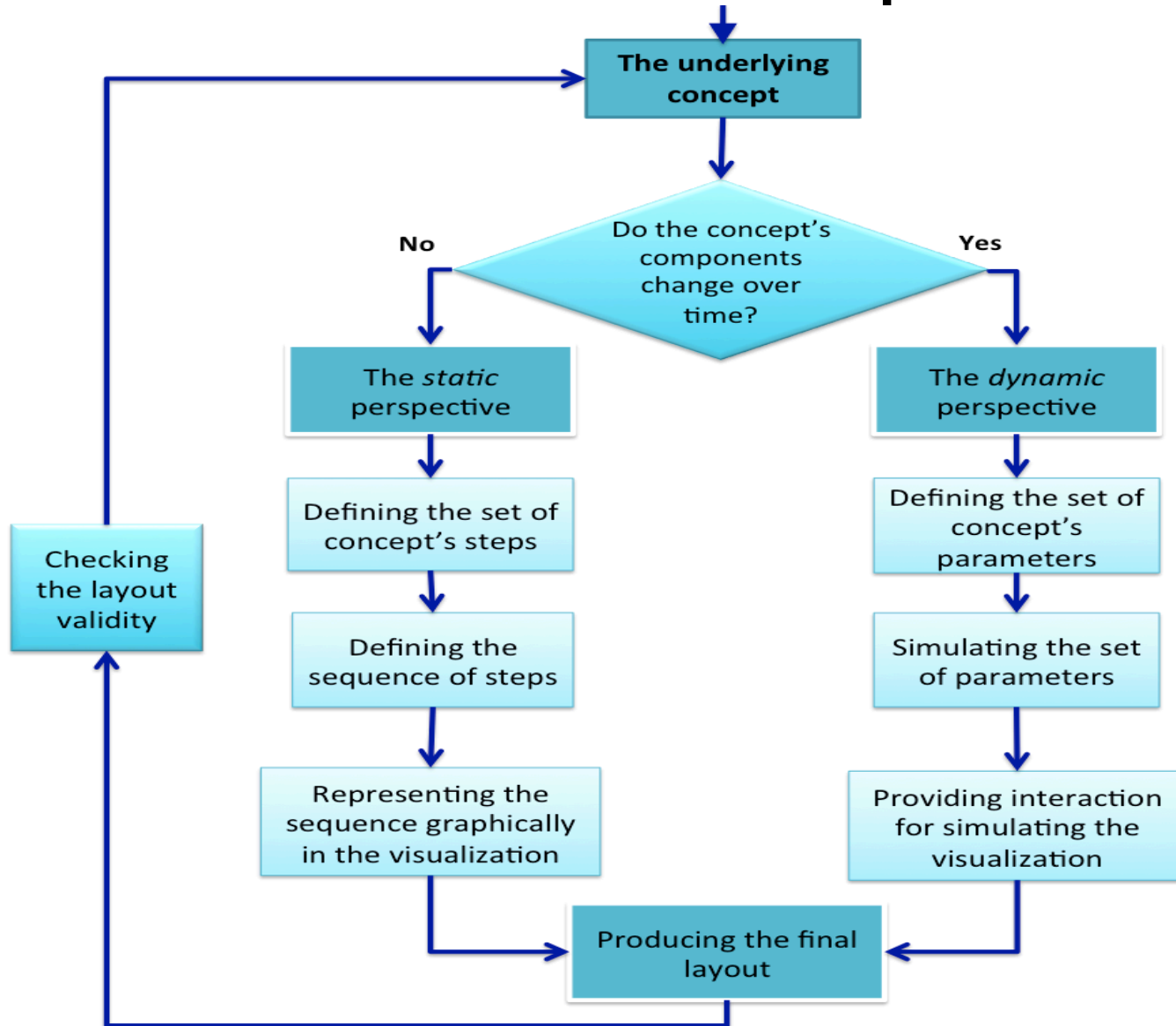

Case Study

- Goal: Enhancing the Understanding of the failure mechanism of the Embedded systems Using the Fault Tree Model.
- Targeted Students: Students at the “Safety and Reliability of Embedded Systems “ course at Kaiserslautern University, (5 students were involved in this study)

Concept Description:

The safety analysis process is based on a method called Fault Trees (FT), which allow to describe the conditions that have to be fulfilled leading to undesired system failures.

The hazardous system-level failure, called Top Event, is represented by the root of the tree where the basic influence factors or failure conditions, called basic events, are represented by the leafs. These elements are logically related via gates (e.g., AND-gate or OR-gate).







Task Description

Show the logical connections in the underlying scenario in which the arrows direction shows the failure propagation among the system modules.

Scenario Description:

The system has two redundant structures and the control unit has two options: the main control unit and the auxiliary control unit. The whole system would be unavailable if both control units are down at the same time. Furthermore, each control unit can be down because of either the corresponding CPU is down or the corresponding power supply is down or both.

The Fault Tree Mechanism

- A Fault detection mechanism
- Top-down approach to trace failures in embedded systems.
- : represents a component
- The or  and the and gate 
- The logical connection represented as 
- The basic event represented as 
- The logical grouping of the set of components is represented as 

Producing Static Visualization of the FT concept

- Students should find out the number of the components in the scenario
- Find out the relations between the existing components.
- And the failure in each component.
- Produce the visualization

Pre-steps

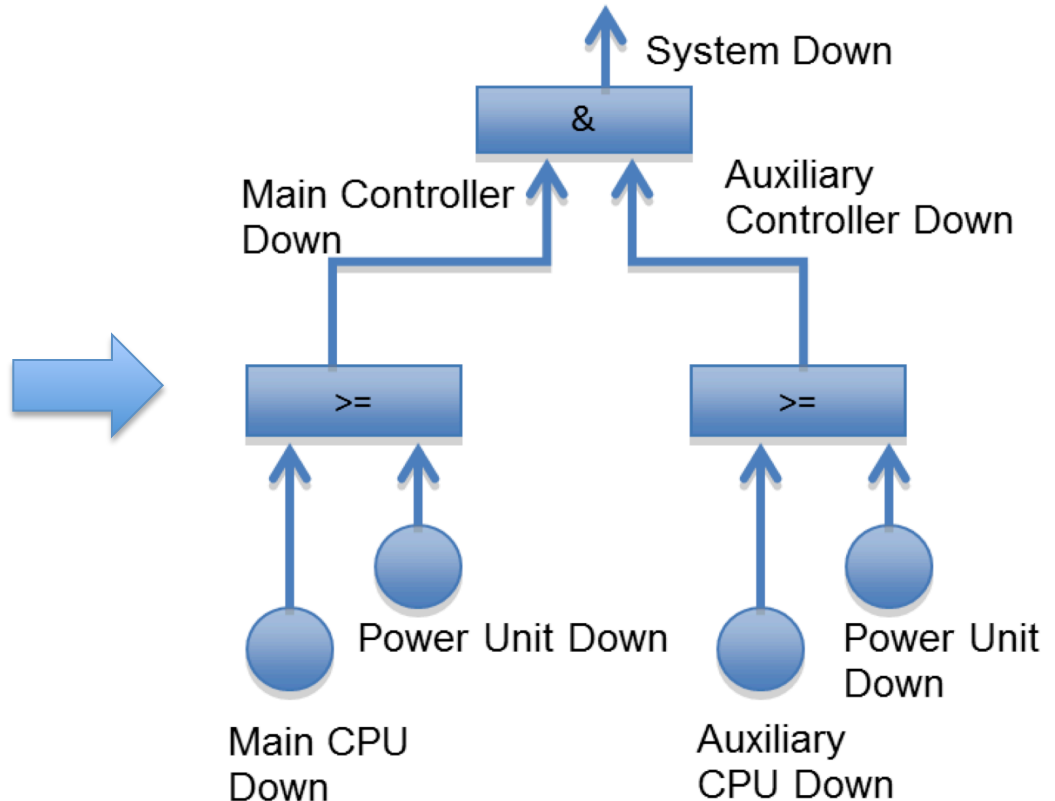

The resulted representation

Convert the static View to a dynamic view

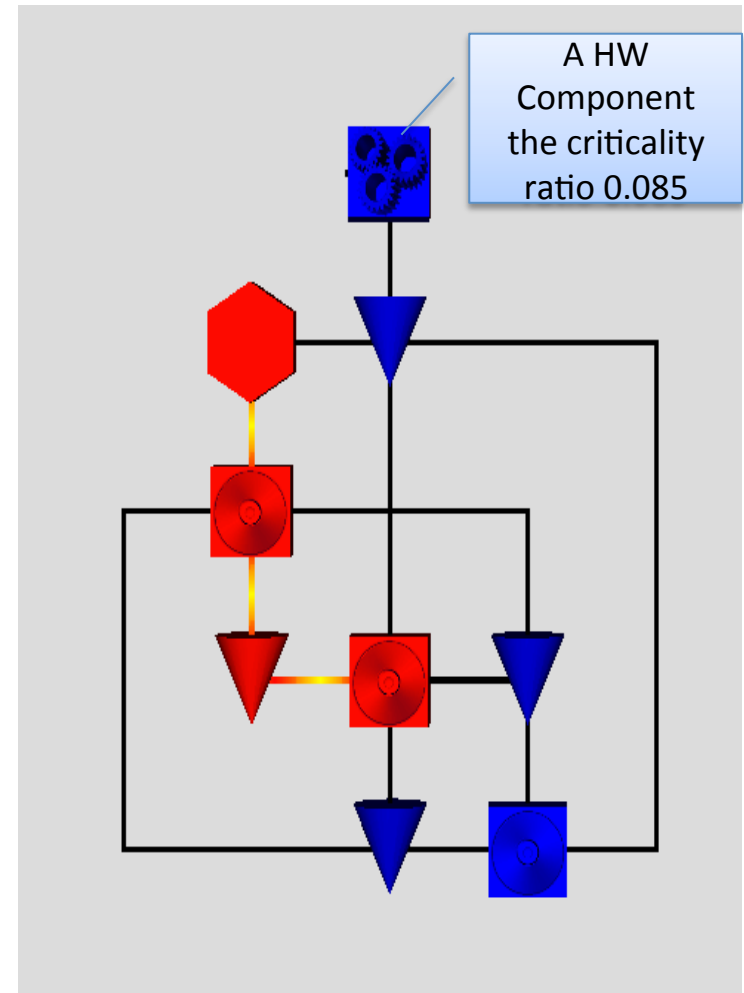
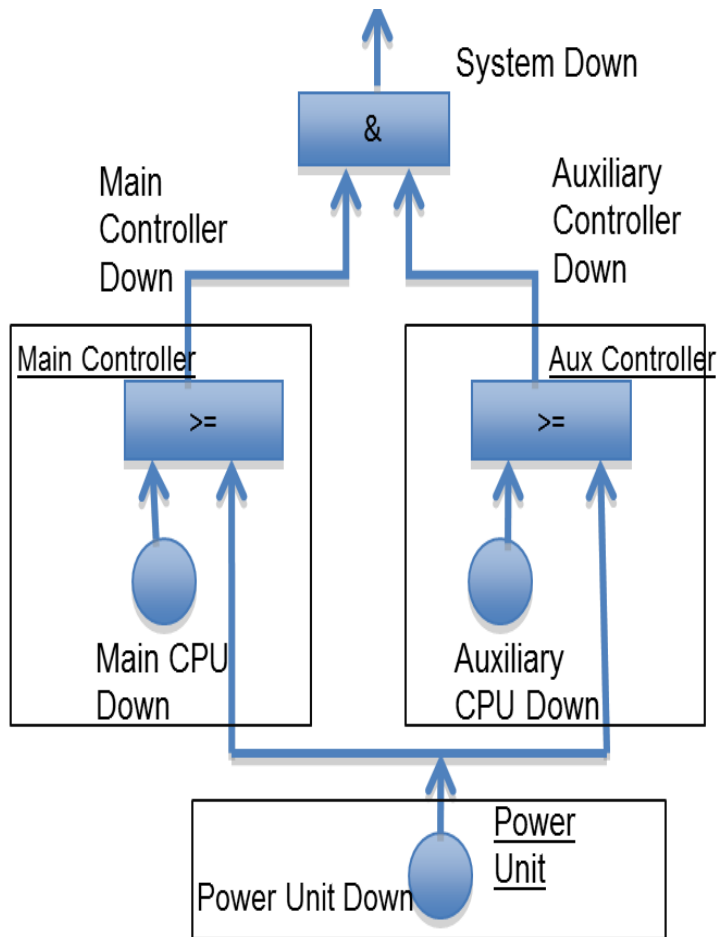

Adding the 3D model of the ES

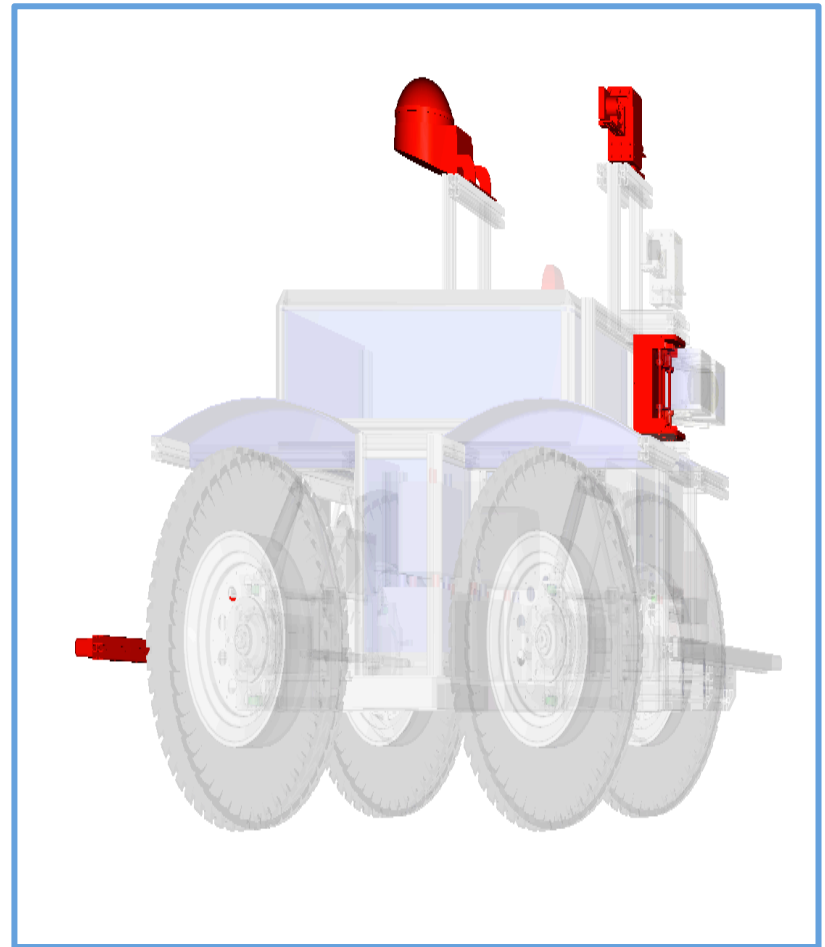
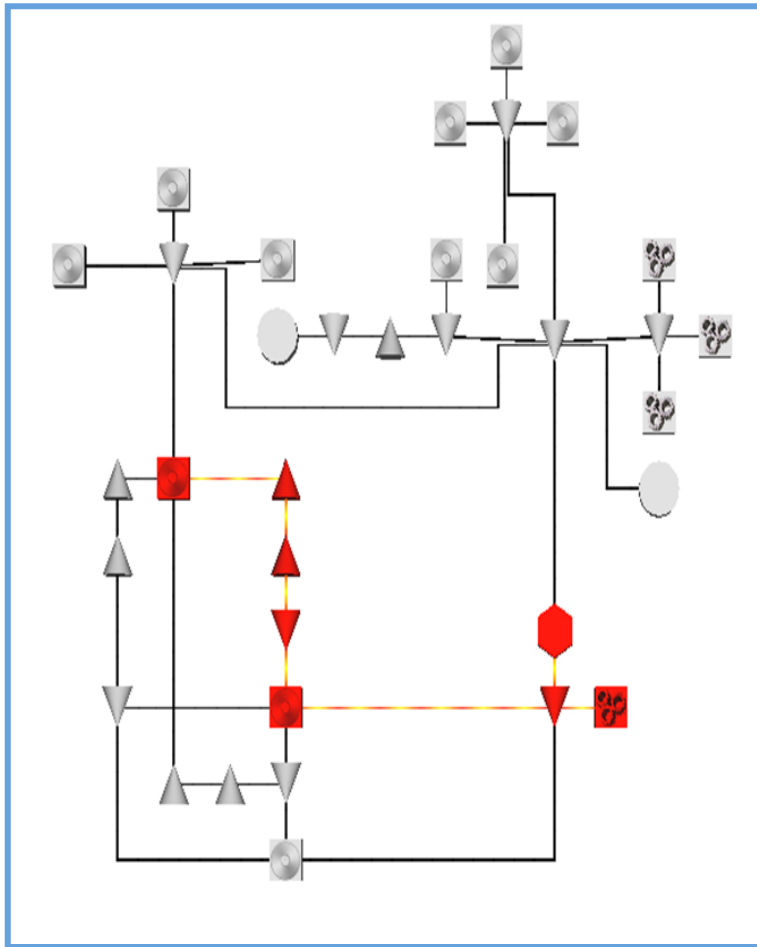

Integration between the abstract representation of the failure mechanism and the real parts in 3D model

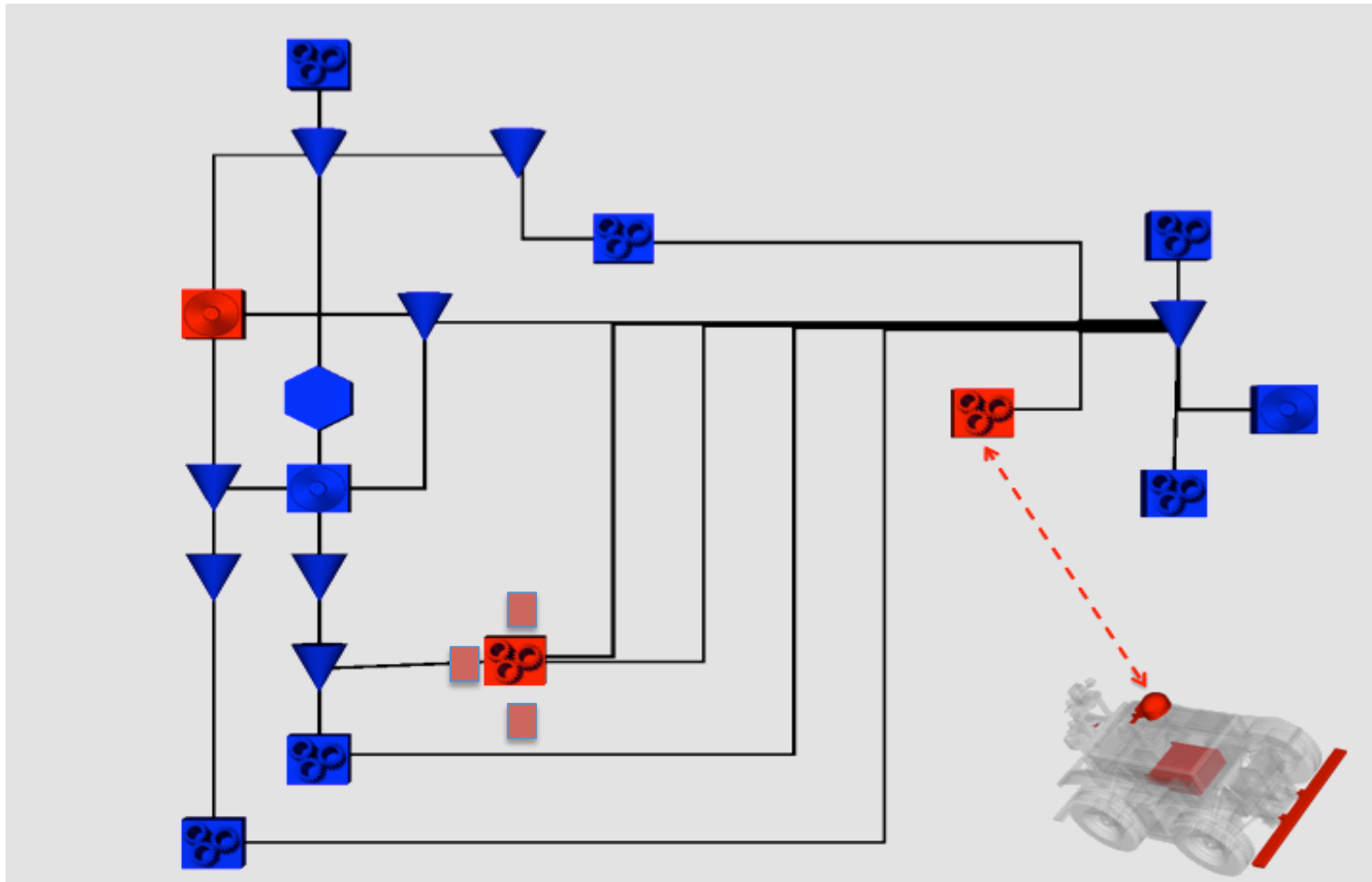

Results and Conclusions

- According to the brief evaluation study of our perspective we conclude the following:
 - Students were able to produce the static visualization by them self if they knew already the meaning of each shape.
 - Converting the concepts into visual forms speeds up the understanding ability of the required concepts.

Results and Conclusions

- The dynamic visualization was used to get more detailed information about the required concept.
- Adding the 3D model of the ES, helps students to map the theoretical meaning of the concept into a real application.

Results and Conclusions

- Students suggested us to optimize the visualizations so they get more information via interacting with the 3D model of the ES.
- Training is an important step For students and teachers.

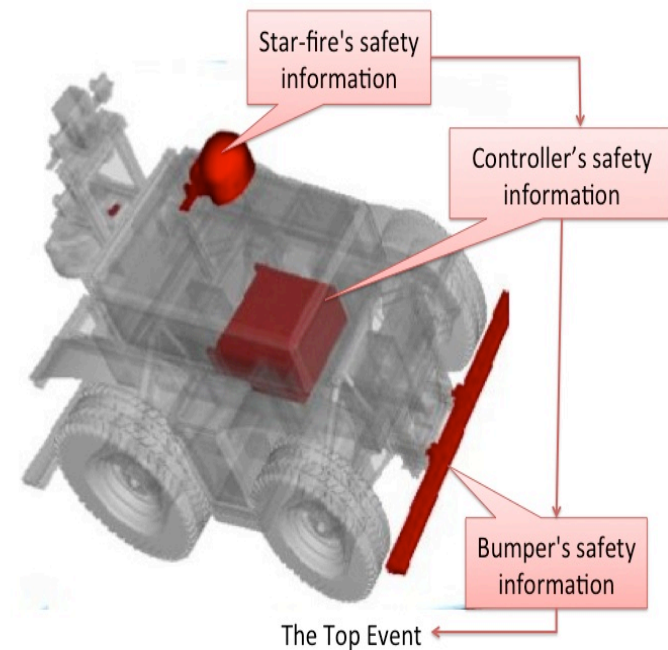



*Thank You For your attention,
Questions !*