



Stichting NIOC en de NIOC kennisbank

Stichting NIOC (www.nioc.nl) stelt zich conform zijn statuten tot doel: het realiseren van congressen over informatica onderwijs en voorts al hetgeen met een en ander rechtstreeks of zijdelings verband houdt of daartoe bevorderlijk kan zijn, alles in de ruimste zin des woords.

De stichting NIOC neemt de archivering van de resultaten van de congressen voor zijn rekening. De website www.nioc.nl ontsluit onder "Eerdere congressen" de gearchiveerde websites van eerdere congressen. De vele afzonderlijke congresbijdragen zijn opgenomen in een kennisbank die via dezelfde website onder "NIOC kennisbank" ontsloten wordt.

Op dit moment bevat de NIOC kennisbank alle bijdragen, incl. die van het laatste congres (NIOC2025, gehouden op donderdag 27 maart 2025 jl. en georganiseerd door Hogeschool Windesheim). Bij elkaar zo'n 1500 bijdragen!

We roepen je op, na het lezen van het document dat door jou is gedownload, de auteur(s) feedback te geven. Dit kan door je te registreren als gebruiker van de NIOC kennisbank. Na registratie krijg je bericht hoe in te loggen op de NIOC kennisbank.

Het eerstvolgende NIOC vindt plaats op 18 maart 2027 in Arnhem en wordt georganiseerd door HAN University of Applied Sciences.

Reacties over de NIOC kennisbank en de inhoud daarvan kun je richten aan de beheerder:

R. Smedinga kennisbank@nioc.nl.

Vermeld bij reacties jouw naam en telefoonnummer voor nader contact.

Kom
verder



Doe het zelf!!!

Met Arduino en Mbed

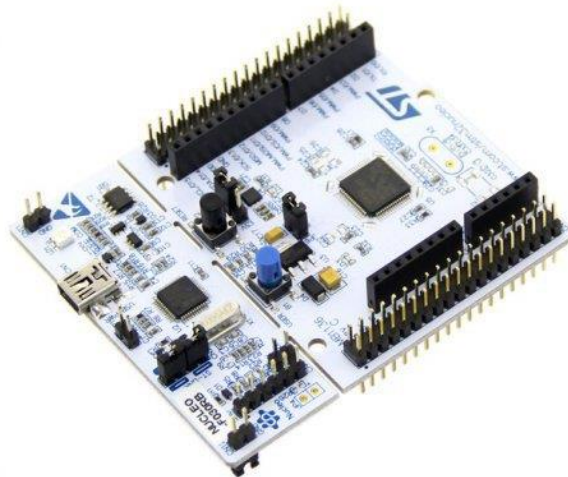
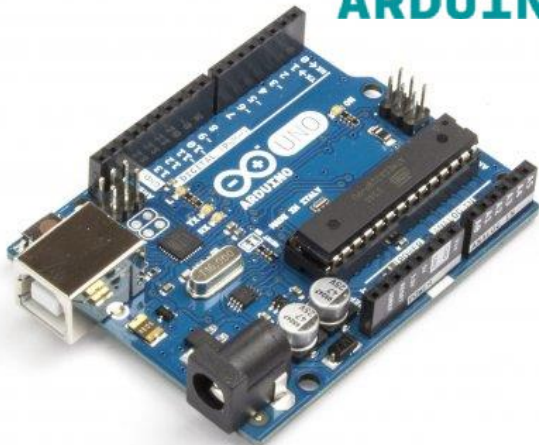

Dr.ir. W.J. (Wilco) Bonestroo

- Docent Informatica
- Onderzoeker bij lectoraat Ambient Intelligence

w.j.bonestroo@saxion.nl

ARM[®]mbed[™]

saxion.nl

Kom
verder



Wat wilt u hier opdoen?



- Ervaring met embedded?
- PO, VO, HO?

Aanleiding

- Do it Yourself (DIY)
- Arduino
- Mbed
- Voorbeeldprojecten
- Aandachtspunten

ICT wordt een telkens belangrijker aspect van ons leven

- Informatica in PO en VO
- Informatica in HO

Hoe enthousiasme voor vak overbrengen?

“Learn to Use” vs. “Use to Learn”

Doel is niet primair leren programmeren

- Problemen oplossen
- Creatief denken
- Technische vaardigheden ontwikkelen

Programmeren is een middel

- Aanleiding
- ➔ Do it Yourself (DIY)
 - Arduino
 - Mbed
 - Voorbeeldprojecten
 - Aandachtspunten

Kom
verder



Do it Yourself (DIY) Maker Movement

Niet alleen software maar juist
ook hardware

Erg aansprekend en vooral leuk

Magische “enchanted” objects

Ears, Eyes, Brain &
communication

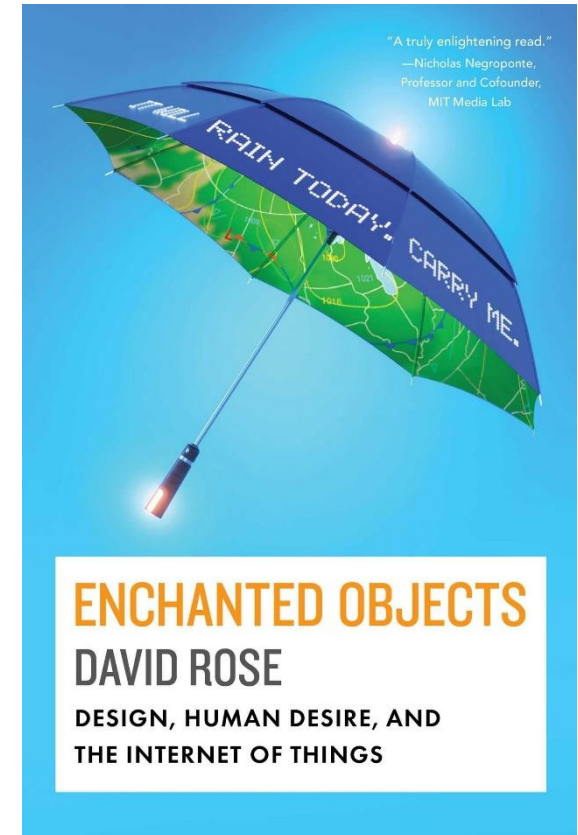

- Aanleiding
- Do it Yourself (DIY)
- ➔ Arduino
- Mbed
- Voorbeeldprojecten
- Aandachtspunten

Wat is Arduino?

Lastige vraag...

- Hardware / Bordjes
- Ontwikkelomgeving (IDE)
- “Programmeertaal”

Arduino is an open-source electronics platform based on easy-to-use hardware and software. It's intended for anyone making interactive projects.



```
void setup() {  
  }  
  
void loop() {  
  }
```

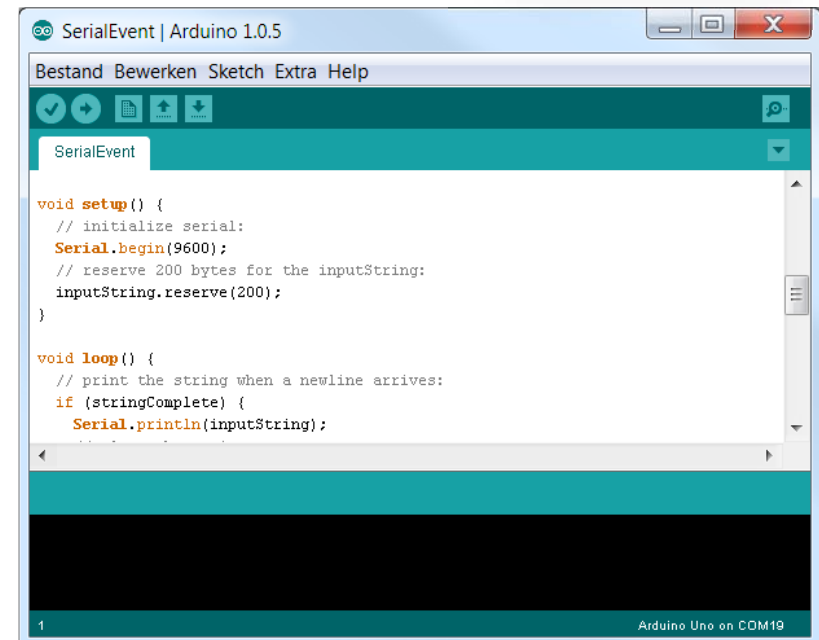

Kom
verder

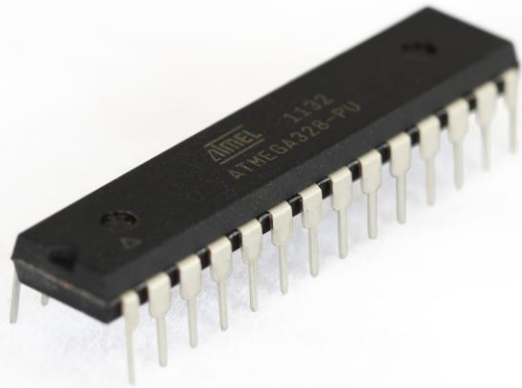

Hello World / Blink

```
/*  
  Blink  
  Turns on an LED on for one second, then off for one second, repeatedly.  
  
  This example code is in the public domain.  
  */  
  
// Pin 13 has an LED connected on most Arduino boards.  
// give it a name:  
int led = 13;  
  
// the setup routine runs once when you press reset:  
void setup() {  
  // initialize the digital pin as an output.  
  pinMode(led, OUTPUT);  
}  
  
// the loop routine runs over and over again forever:  
void loop() {  
  digitalWrite(led, HIGH); // turn the LED on (HIGH is the voltage level)  
  delay(1000);             // wait for a second  
  digitalWrite(led, LOW);  // turn the LED off by making the voltage LOW  
  delay(1000);             // wait for a second  
}
```

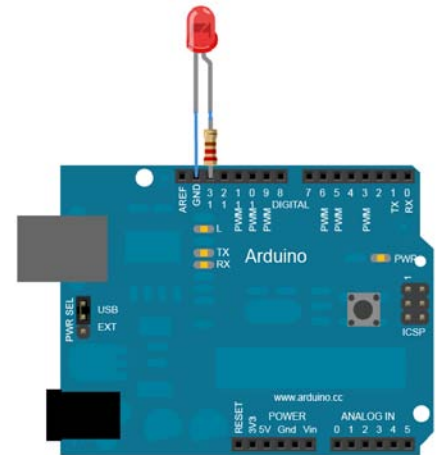

Arduino Community

- Arduino.cc
- Tutorials / Arduino day
- Bordjes variëren in prijs (max. 20 euro)
- Kits (max 200 euro)



- Aanleiding
- Do it Yourself (DIY)
- Arduino
- ➔ Mbed
- Voorbeeldprojecten
- Aandachtspunten

- Zelfde principe als Arduino
- Meerdere producenten
 - NXP, Nordic, STMicroelectronics, FreeScale, enz.



Installatie verschillend per producent / board

Kom verder



Online IDE / Mbed Compiler

The screenshot displays the mbed online IDE interface. The browser address bar shows the URL: https://developer.mbed.org/compiler/#nav:/Nucleo_blink_led/main.cpp. The IDE title is "mbed /Nucleo_blink_led/main.cpp". The menu bar includes options like New, Import, Save, Save All, Compile, Commit, Revisions, and Help. The "Program Workspace" on the left shows a tree view with "My Programs", "Nucleo_blink_led", "main.cpp", and "mbed". The main editor displays the following C++ code:

```
1 #include "mbed.h"
2
3 DigitalOut myled(LED1);
4
5 int main() {
6     while(1) {
7         for (uint8_t i=0; i < 50; i++)
8         {
9             myled = 1; // LED is ON
10            wait(0.05); // 200 ms
11            myled = 0; // LED is OFF
12            wait(0.05);
13        }
14        wait(5.0); // 5 sec
15    }
16 }
```

Below the code editor, the "Compile output for program: Nucleo_blink_led" section shows "Errors: 0", "Warnings: 0", and "Infos: 0". A table with columns "Description", "Error Number", "Resource", and "In Folder" is present but empty. At the bottom, there are tabs for "Compile Output", "Find Results", and "Notifications" (with a red badge showing "2"). The status bar at the very bottom indicates "Ready." and shows cursor coordinates: "In 1 col 1 18 INS".

Kom
verder



STMicroelectronics

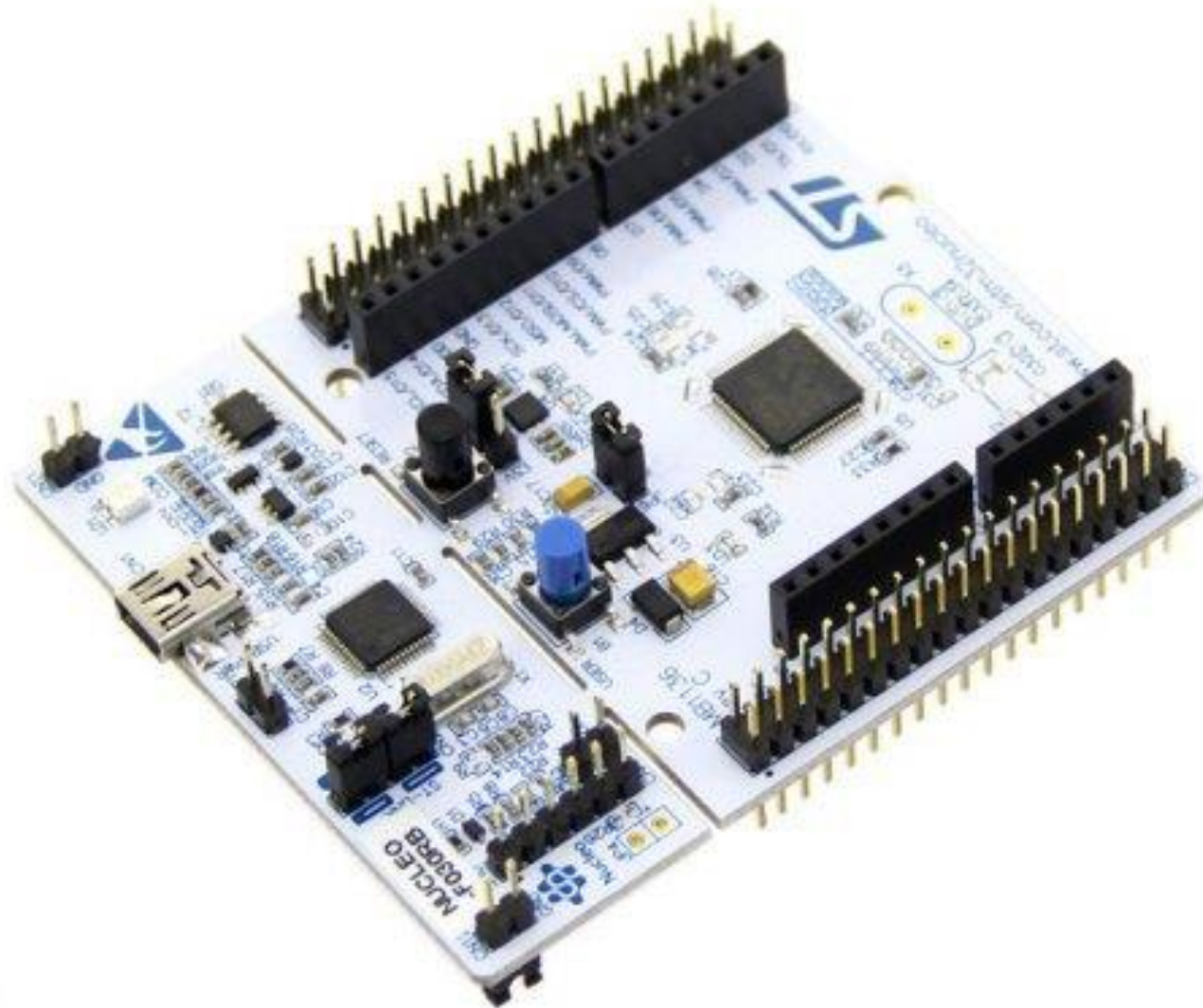

Kom
verder



Hello World / Blink

```
main.cpp x AnalogIn x AnalogOut x main.cpp x main.cpp x
1 #include "mbed.h"
2
3 Ticker toggle_led_ticker;
4
5 DigitalOut led1(LED1);
6
7 void toggle_led() {
8     led1 = !led1;
9 }
10
11 int main() {
12     // Init the ticker with the address of the function (toggle_led) to be attached and the interval (100 ms)
13     toggle_led_ticker.attach(&toggle_led, 0.1);
14     while (true) {
15         // Do other things...
16     }
17 }
18
```

```
main.cpp x AnalogIn x AnalogOut x
1 #include "mbed.h"
2
3 DigitalOut myled(LED1);
4
5 int main() {
6     while(1) {
7         myled = 1; // LED is ON
8         wait(0.2); // 200 ms
9         myled = 0; // LED is OFF
10        wait(1.0); // 1 sec
11    }
12 }
```

- Aanleiding
- Do it Yourself (DIY)
- Arduino
- Mbed
- ➔ Voorbeeldprojecten
- Aandachtspunten

Kom
verder

SAXION

Voorbeeldprojecten

Studentenbloempot



Kom
verder



Voorbeeldprojecten

Brievenbus & Wasmachine



- Aanleiding
- Do it Yourself (DIY)
- Arduino
- Mbed
- Voorbeeldprojecten
- ➔ Aandachtspunten

Aandachtspunten

- Programmeren in C/C++
 - Steile leercurve
 - Lastig debuggen
- Componenten

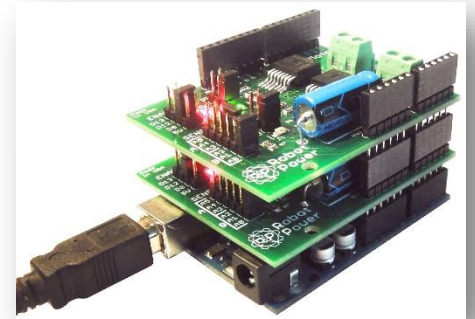
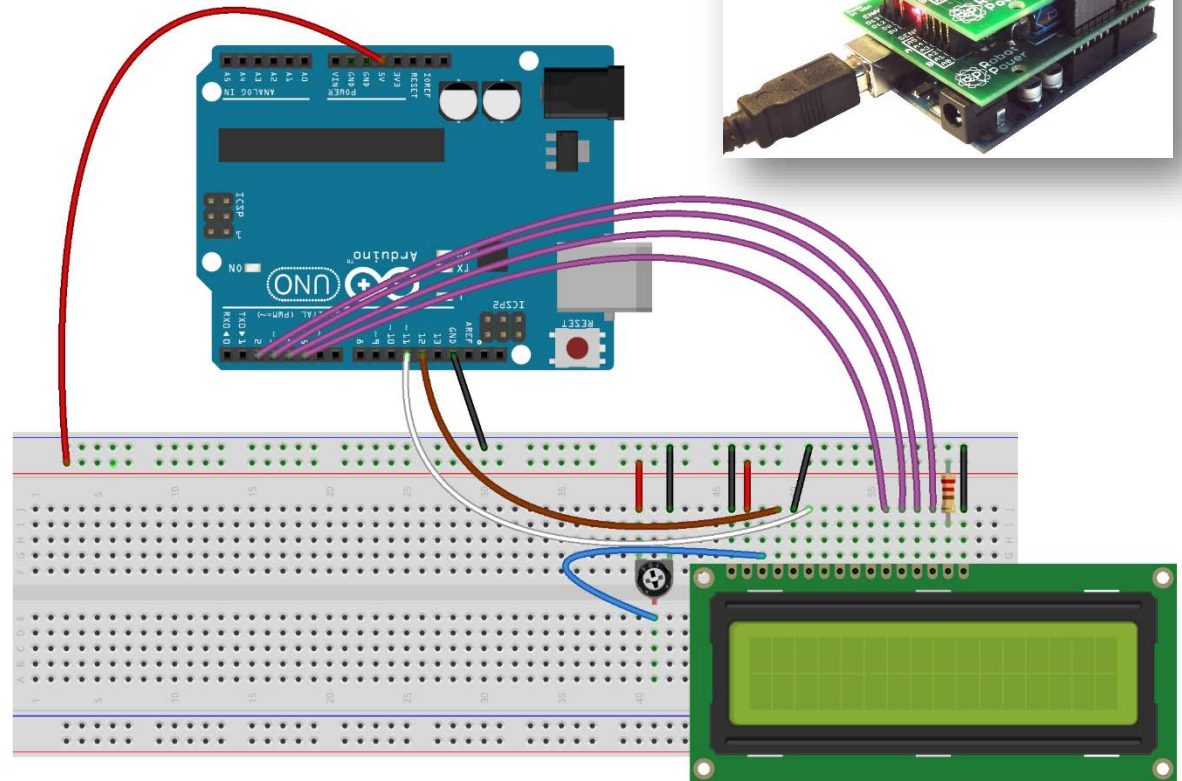
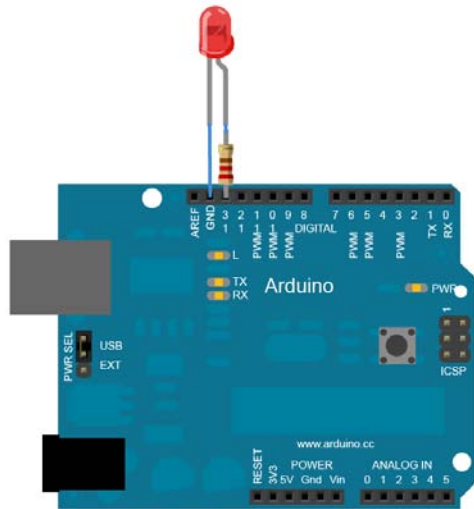

Kom verder



Aandachtspunten

Componenten

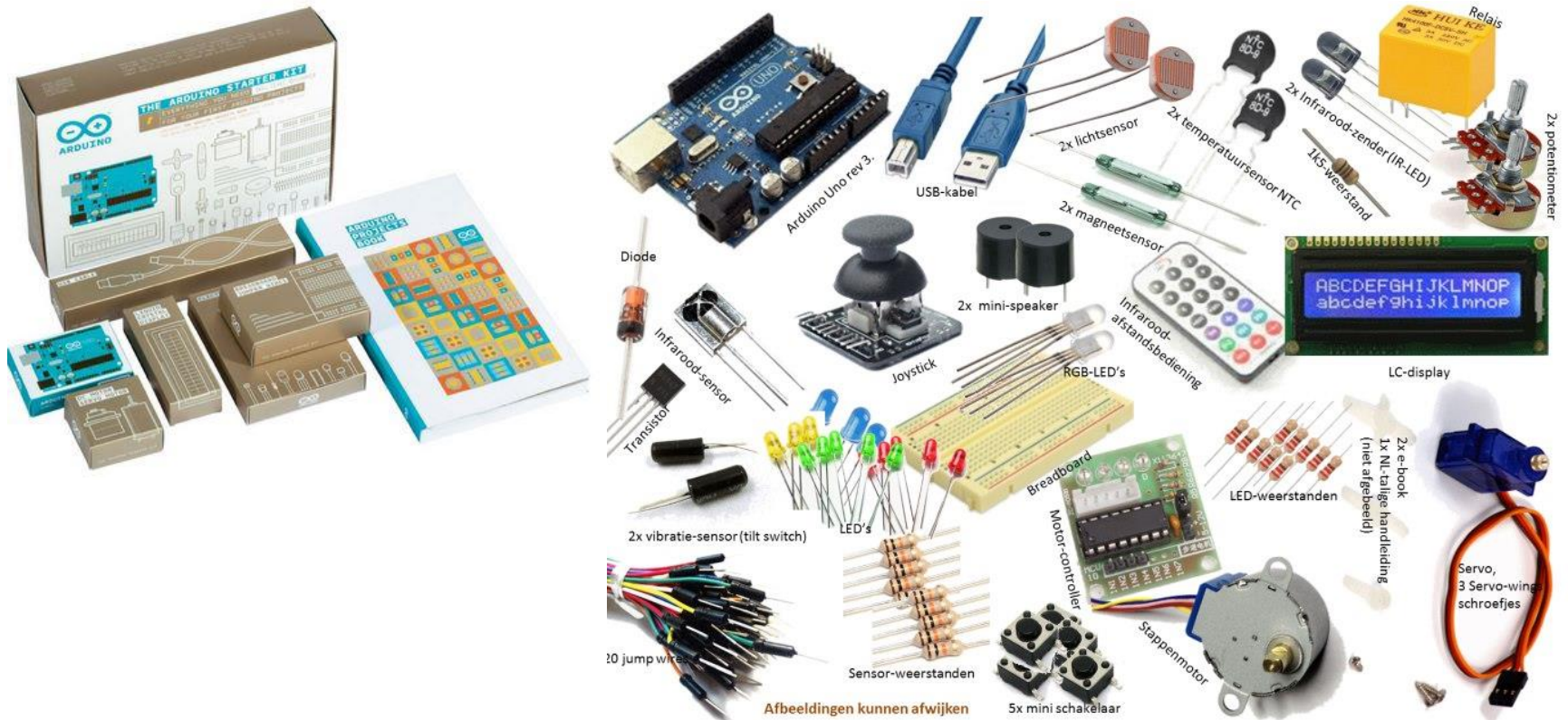

Extra hardware

Basis:

- Multimeter
- Soldeerspullen
- Externe voeding

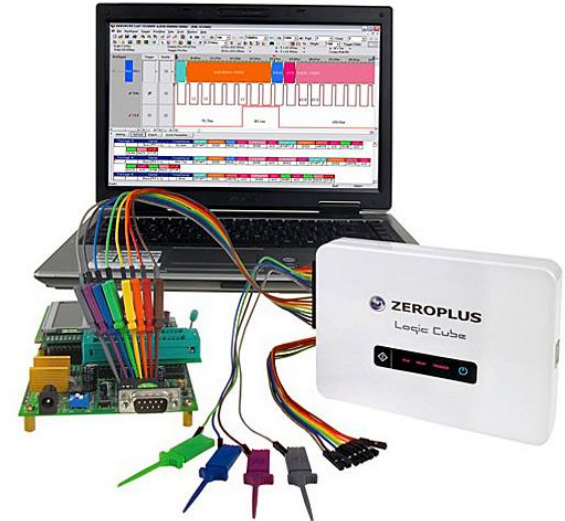

Geavanceerd:

- Logical Analyser
- Programmer / Debugger

